

105Ah Lithium Battery

with Bluetooth & Heating

FOXYGEN

DATA SHEET



100A BMS



BLUETOOTH



HEATING

Model Included:

FOX12V-105AH

Our Foxygen 12V 105Ah LiFePO₄ Battery comes with Bluetooth, Switchable Heating and an unrivalled 12 Year Warranty.

Electrical Specifications

Nominal Voltage	12.8V
Nominal Capacity	105Ah
Parallel Connection	Max. 6 Units
Serial Connection	Max. 4 Units
BMS	4S100A
Bluetooth	Android/iOS
Heat	Yes (Switchable)
Circuit Protection	Overcharge, Overdischarge, Overcurrent, Over Temp., Under Temp., Short Circuit
Cycle Life	6000times @80% DOD
Self Discharge	Less than 3% per month
Charge Efficiency	100% @0.2C
Discharge Efficiency	98-100% @1C

Charge Specifications

Charge Voltage	14.4V ± 0.2V
Standard Current	21A
Fast Current	62.5A

105Ah Lithium Battery

with Bluetooth & Heating

FOXYGEN

DATA SHEET

Discharge Specifications

Standard Current	21A
Max. Continuous Current	100A
Cut-Off Voltage	10V

Mechanical Specifications

Dimensions (mm)	260mm × 170mm × 208mm
Approx. Weight (kg)	10.64kg
Terminal Type	M8
Case Colour/Material	Black Plastic Case (ABS)
IP Rating	IP65
Cell Type	3.2V 105Ah Prismatic Cell
Cell Balancing	Passive
Cell Configuration	4S1P

Temperature Specifications

Charge Temp.	-20°C to 55°C (-4°F to 131°F)
Discharge Temp.	-20°C to 60°C (-4°F to 140°F)
Storage Temp.	-5°C to 45°C (23°F to 113°F)

105Ah Lithium Battery

with Bluetooth & Heating

FOXYGEN

DATA SHEET

Quality Control Highlights

- Each battery pack is produced under strict quality control standards. Cells are carefully matched, with the internal resistance difference limited to just **1 mΩ** and the voltage difference restricted to **5 mV**. To ensure reliability and consistency, all cells are laser welded using fully automated equipment, minimizing human error and improving long-term performance.
- Before packaging, every battery pack undergoes a **100% cycle test**, which includes the sequence: fully discharged, fully charged, fully discharged again, and finally recharged to 60%. The results of these tests are recorded and stored for traceability, ensuring that each pack meets both safety and performance requirements.
- For additional quality tracking, each battery pack is laser-etched with a unique identification number on the side of the case. This allows every unit to be individually monitored throughout its lifecycle, from production to field use.

Certifications

- UL1973 (Cell)
- UL9540A (Cell)
- IEC62660 (Cell)
- IEC62619 (Cell)
- UL2580 (Cell)
- CE (Cell / Pack)
- UN38.3 (Cell / Pack)
- ROHS (Cell)



105Ah Lithium Battery

with Bluetooth & Heating

FOXYGEN

DATA SHEET

Battery Dimensions

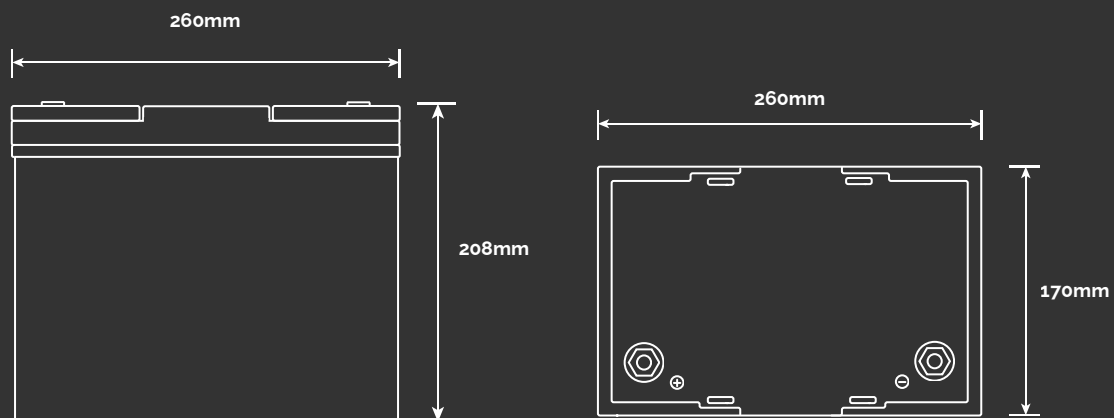

Internal View

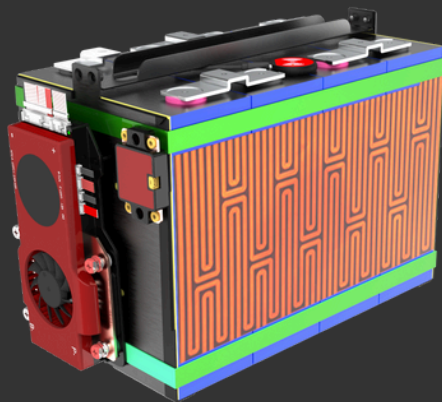

105Ah Lithium Battery

with Bluetooth & Heating

DATA SHEET

FOXYGEN

Characteristics Curve

Charging Characteristics (0.5C @25°C)

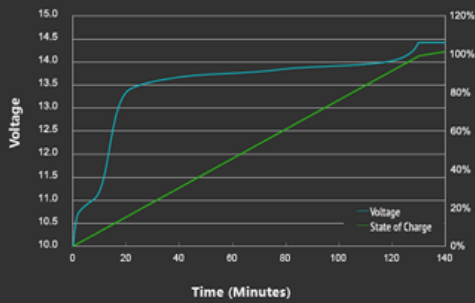

Discharging Characteristics (0.2C, 0.5C, 1C @25°C)

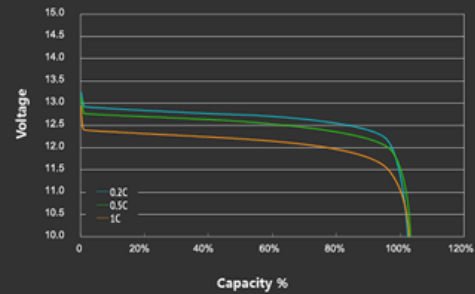

Different Temperature Capacity Curve

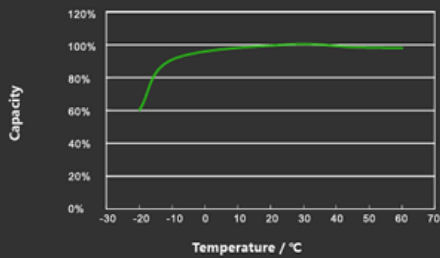

Typical Charge Time Curve

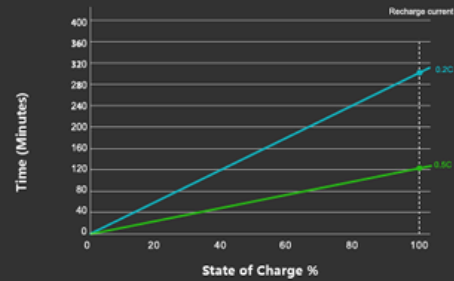

Different Temperature Self Discharge Curve

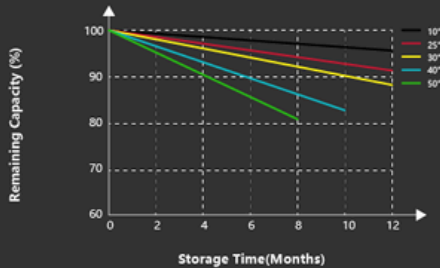

Different DOD Discharge Cycle Life Curve

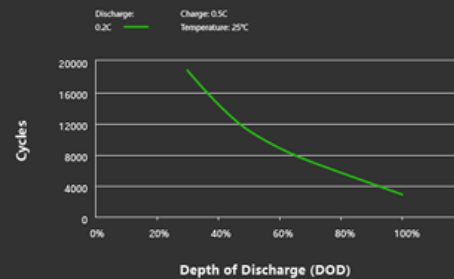

105Ah Lithium Battery

with Bluetooth & Heating

FOXYGEN

DATA SHEET

Key Benefits

- **High-Quality Prismatic Cells**

The battery is built with advanced prismatic cells that are certified to **UL1973**, **UL9540**, **IEC62133**, and **IEC62619** standards. These cells deliver a cycle life of more than **3,000 cycles** @100% DOD while maintaining excellent consistency and reliability over time.

- **Bluetooth Connectivity**

An integrated Bluetooth system provides real-time monitoring of key battery parameters, including charge and discharge status, current, temperature, and cycle life. It also allows configuration adjustments for different applications, offering flexibility and enhanced control.

- **Intelligent Heating System**

For cold-weather performance, the battery features a uniform internal heating system that ensures the cells are warmed evenly. Unlike external heating blankets, which cannot sense internal cell temperature and often heat unevenly, this proprietary system draws power directly from the charging source and requires no additional components. The process is completely seamless, simply connect the battery to any compatible lithium charger, and the built-in heating and monitoring system automatically manages both heating and charging.

- **High Energy Density, Lower Weight**

With an energy density approximately **15% higher** than conventional cells, the battery provides more power while reducing overall weight. This results in a lighter, more efficient solution without compromising performance.

Market Applications



RV



Marine



Golf cart



Cleaning



Light EV



Energy storage



Robotics



Lighting

105Ah Lithium Battery

with Bluetooth & Heating

FOXYGEN

DATA SHEET

Package

20' Container = 10 Pallets = 900 Cartons = 900 Units
40' Container = 20 Pallets = 1800 Cartons = 1800 Units



Protective pearl foam packaging



Weight: 11 kg/carton size (L×W×H)
320mm × 230mm × 282mm

1 Carton = 1 Unit



Weight: 1005 kg/pallet size (L×W×H)
1.2m × 1m × 1.8m = 2.2m³

1 Pallet = 90 Cartons