

# 300Ah Lithium Battery

with Bluetooth & Heating

# FOXYGEN

## DATA SHEET



250A BMS



BLUETOOTH



HEATING

## Model Included:

**FOX12V-300AH**

Our Foxygen 12V 300Ah LiFePO<sub>4</sub> Battery comes with Bluetooth, Switchable Heating and an unrivalled 12 Year Warranty.

### Electrical Specifications

Nominal Voltage	12.8V
Nominal Capacity	300Ah
Parallel Connection	Max. 6 Units
Serial Connection	Max. 4 Units
BMS	4S250A
Bluetooth	Android/iOS
Heat	Yes (Switchable)
Circuit Protection	Overcharge, Overdischarge, Overcurrent, Over Temp., Under Temp., Short Circuit
Cycle Life	6000 times @80% DOD
Self Discharge	Less than 3% per month
Charge Efficiency	100% @0.2C
Discharge Efficiency	98-100% @1C

### Charge Specifications

Charge Voltage	14.4V ± 0.2V
Standard Current	60A
Fast Current	150A

# 300Ah Lithium Battery

with Bluetooth & Heating

# FOXYGEN

## DATA SHEET

### Discharge Specifications

Standard Current	60A
Max. Continuous Current	250A
Cut-Off Voltage	10V

### Mechanical Specifications

Dimensions (mm)	367mm × 190mm × 245mm
Approx. Weight (kg)	26.52kg
Terminal Type	M8
Case Colour/Material	Black Plastic Case (ABS)
IP Rating	IP65
Cell Type	3.2V 304Ah Prismatic Cell
Cell Balancing	Passive
Cell Configuration	4S1P

### Temperature Specifications

Charge Temp.	-20°C to 55°C (-4°F to 131°F)
Discharge Temp.	-20°C to 60°C (-4°F to 140°F)
Storage Temp.	-5°C to 45°C (23°F to 113°F)

# 300Ah Lithium Battery

with Bluetooth & Heating

# FOXYGEN

## DATA SHEET

### Quality Control Highlights

- Each battery pack is produced under strict quality control standards. Cells are carefully matched, with the internal resistance difference limited to just **1 mΩ** and the voltage difference restricted to **5 mV**. To ensure reliability and consistency, all cells are laser welded using fully automated equipment, minimizing human error and improving long-term performance.
- Before packaging, every battery pack undergoes a **100% cycle test**, which includes the sequence: fully discharged, fully charged, fully discharged again, and finally recharged to 60%. The results of these tests are recorded and stored for traceability, ensuring that each pack meets both safety and performance requirements.
- For additional quality tracking, each battery pack is laser-etched with a unique identification number on the side of the case. This allows every unit to be individually monitored throughout its lifecycle, from production to field use.

### Certifications

- UL1973 (Cell)
- UL9540A (Cell)
- IEC62660 (Cell)
- IEC62619 (Cell)
- UL2580 (Cell)
- CE (Cell / Pack)
- UN38.3 (Cell / Pack)
- ROHS (Cell)



# 300Ah Lithium Battery

with Bluetooth & Heating

# FOXYGEN

## DATA SHEET

### Battery Dimensions

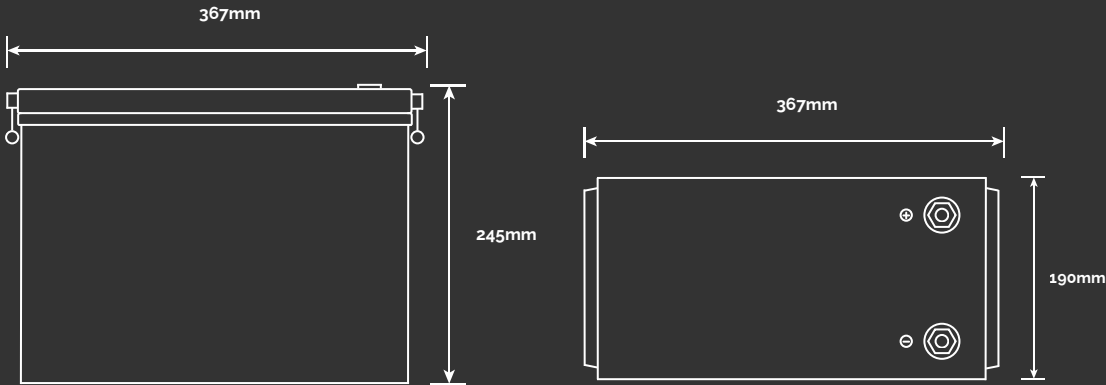

### Internal View

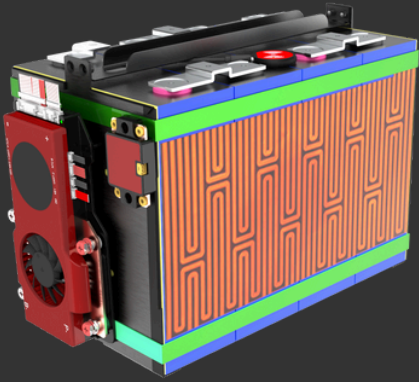

# 300Ah Lithium Battery

with Bluetooth & Heating

## DATA SHEET

# FOXYGEN

### Characteristics Curve

#### Charging Characteristics (0.5C @25°C)

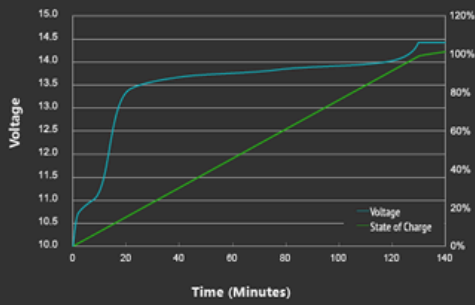

#### Discharging Characteristics (0.2C, 0.5C, 1C @25°C)

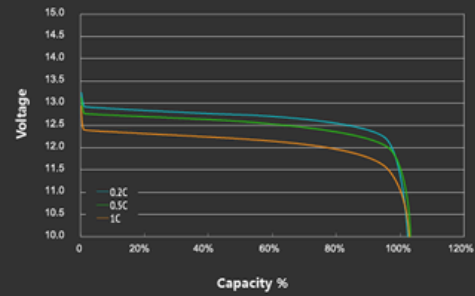

#### Different Temperature Capacity Curve

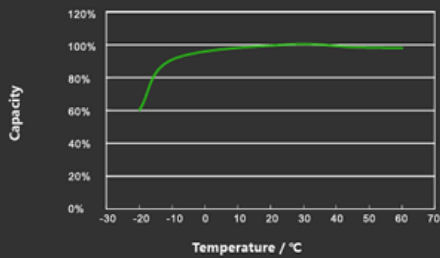

#### Typical Charge Time Curve

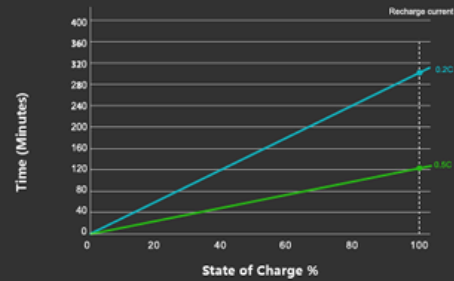

#### Different Temperature Self Discharge Curve

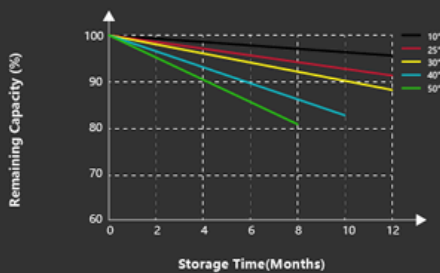

#### Different DOD Discharge Cycle Life Curve

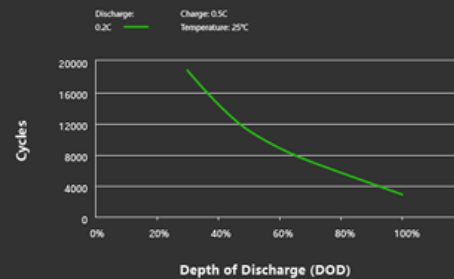

# 300Ah Lithium Battery

with Bluetooth & Heating

# FOXYGEN

## DATA SHEET

### Key Benefits

- **High-Quality Prismatic Cells**

The battery is built with advanced prismatic cells that are certified to **UL1973**, **UL9540**, **IEC62133**, and **IEC62619** standards. These cells deliver a cycle life of more than **3,000 cycles** @100% DOD while maintaining excellent consistency and reliability over time.

- **Bluetooth Connectivity**

An integrated Bluetooth system provides real-time monitoring of key battery parameters, including charge and discharge status, current, temperature, and cycle life. It also allows configuration adjustments for different applications, offering flexibility and enhanced control.

- **Intelligent Heating System**

For cold-weather performance, the battery features a uniform internal heating system that ensures the cells are warmed evenly. Unlike external heating blankets, which cannot sense internal cell temperature and often heat unevenly, this proprietary system draws power directly from the charging source and requires no additional components. The process is completely seamless, simply connect the battery to any compatible lithium charger, and the built-in heating and monitoring system automatically manages both heating and charging.

- **High Energy Density, Lower Weight**

With an energy density approximately **15% higher** than conventional cells, the battery provides more power while reducing overall weight. This results in a lighter, more efficient solution without compromising performance.

### Market Applications



RV



Marine



Golf cart



Cleaning



Light EV



Energy storage



Robotics



Lighting

# 300Ah Lithium Battery

with Bluetooth & Heating

# FOXYGEN

## DATA SHEET

### Package

20' Container = 10 Pallets = 480 Cartons = 480 Units  
40' Container = 20 Pallets = 960 Cartons = 960 Units



Protective pearl foam packaging



Weight: 27 kg/carton size (L×W×H)  
400mm × 240mm × 295mm

1 Carton = 1 Unit

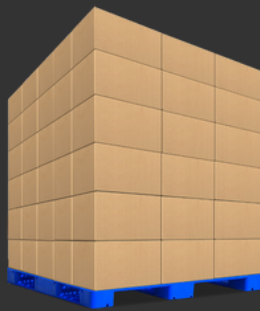

Weight: 1311 kg/pallet size (L×W×H)  
1.2m × 1m × 1.4m = 1.7m<sup>3</sup>

1 Pallet = 48 Cartons